

JUXTA F Series Instruction Manual

Model FHFA/V
Super Speed Isolator

JUXTA

1. INSPECTION

This instrument has been thoroughly tested at the factory before shipment. When you receive it, visually inspect it for damage and check the accessories.

1.1 Model number and specification check

Check to see the model number and specifications on the nameplate attached to the front cover of the instrument are as ordered.

1.2 Contents of the instruction manual

This instruction manual provides instructions on how to mount, wire externally and maintain the instrument.

2. GENERAL

This instrument receives DC current or voltage signals and converts them into isolated current or voltage signals.

Accessories:	Mounting block		2
	Tag number label		1
	Mounting screw	M4	2

3. MOUNTING METHOD

JUXTA signal conditioners can be mounted on racks, walls or DIN rails.

3.1 Rack mounting

Use panel (FRK-16) and install it on an angle as shown in Fig.1. This is a convenient method for high density mounting of the instrument on 19-inch rack panel. (See Fig. 7.)

3.2 Wall mounting

Use panel (FRK-16) to mount the instrument on the wall as shown in Fig. 2 or directly mount it on the wall. (See Figs. 7 and 8 for mounting dimensions.)

3.3 DIN rail mounting

Insert a DIN rail into the upper section of the instrument and lock the rail in position by the slide lock at the base of the instrument as shown in Figs. 3 and 4.

3.4 Angle mounting

If the instrument is mounted without using the panel (FRK-16), refer to Fig. 5 for its mounting.

3.5 Mounting block installation and removal

Insert a mounting block into groove of the instrument and slide it until it locks in position by the stopper as shown in Fig.6. To remove it, lift up stopper by the screwdriver (-) and slide the mounting block along the groove.

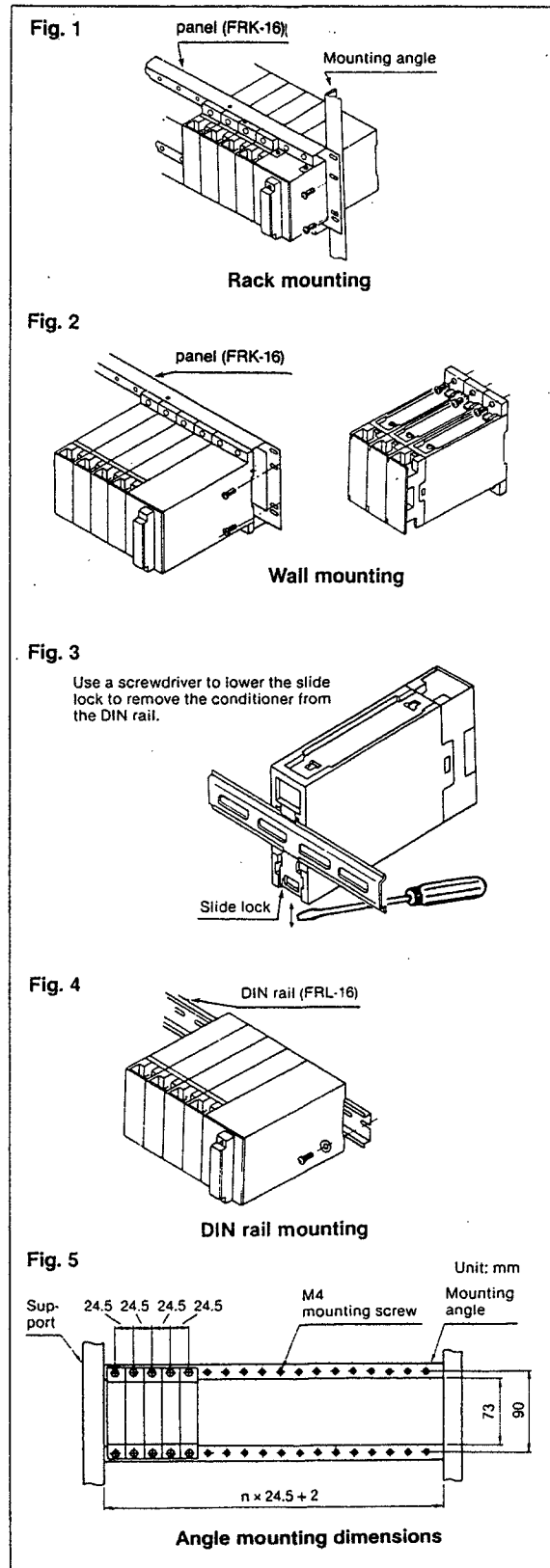

4. EXTERNAL WIRING

Open the terminal cover of the instrument and wire the terminals. Flexible twisted wire and good contact of durable round crimp-on terminals (JIS C2805) are recommended to be used.

4.1 Signal cable

Nominal cross-sectional area of conductor:
0.5 to 0.75 mm²

Example of suitable cable:

Twisted vinyl cord (VSF) (JIS C3306)

4.2 Power cable

Nominal cross-sectional area of conductor:
1.25 to 2.00 mm²

Example of suitable cable:

Twisted 600V vinyl cord (IV) (JIS C3307)

4.3 Wiring

- ① See Fig. 9 for the terminal arrangement.
- ② Connect input voltage signal cable to isolator terminals 2(+) and 3(-).
- ③ Connect isolator output signal cable to its terminals 4(+) and 5(-).
- ④ Connect 24V DC power supply to isolator terminals 6(+), 7(-). (See Fig.10)

5. ITEMS TO BE CHECKED BEFORE TURNING THE POWER SWITCH ON

- ① Make sure that 24V DC power supply of the isolator is connected to the correct polarities, (+) (-).
- ② Confirm that the external wiring to the terminal board is correct.
- ③ Check that the mounting, ambient temperature, humidity, dust and vibration are normal. Confirm the above items before turning on the power supply. The isolator needs 5 minutes warmup to meet its specified accuracy levels.

6. MAINTENANCE

(Caution)

Carry out the following calibration after warming up the isolator for more than 5 minutes.

6.1 Calibration equipment

- Voltage/current generator (Yokogawa model 2553 or equivalent) 1
- Voltmeter (Yokogawa model 2502A or equivalent) 1
- Precision resistor of 250Ω ±0.01%, 1W 1 (when current output)

6.2 Calibration

- ① Connect equipment as shown in Fig.11.
- ② Input/output characteristic check
Use voltage/current generator and apply input signals equivalent to 0, 25, 50, 75 and 100% to the isolator. Check that corresponding isolator outputs are 0, 25, 50, 75 and 100% respectively and are within specified accuracy rating range.
*If output signal is out of tolerance, adjust it by the span and zero adjustment trimmers on the front panel of the instrument.

Fig. 6

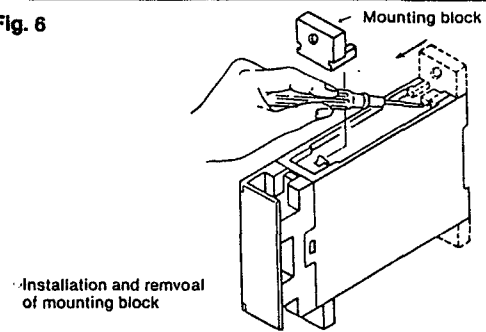

Installation and removal of mounting block

Fig. 7

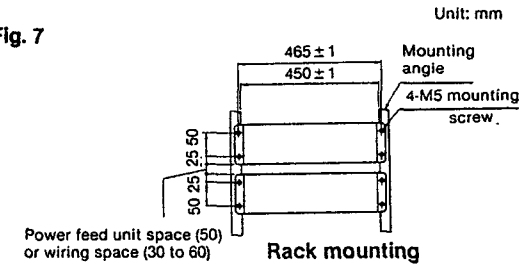

Power feed unit space (50) or wiring space (30 to 60)

Rack mounting dimensions

Fig. 8

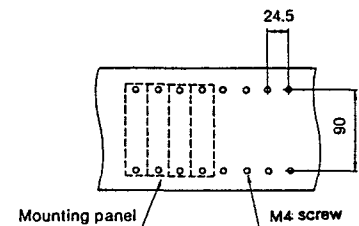

Panel (wall) mounting dimensions

Fig. 9

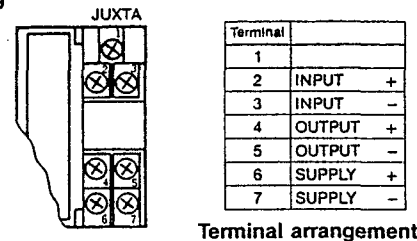

Terminal arrangement

Fig. 10

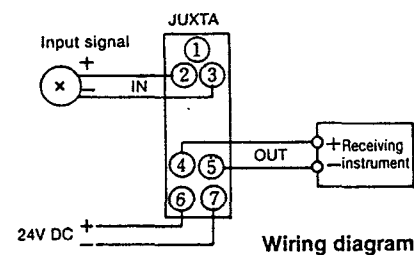

Wiring diagram

Fig. 11

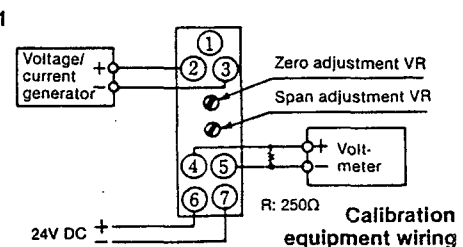

Calibration equipment wiring

Subject to change without notice for grade up quality and performance.